



SEER Push-To-Start System & Relay Module

INSTALLATION AND

OPERATION MANUAL



For the most recent version of this document visit vaistech.com or scan the QR code.



CONTENTS

Installation Route.....	4
Included Parts.....	5
Safety.....	6
Installation Section	
SEER System Wiring Diagram.....	9
Antennas Installation.....	11
Push-to-Start Button Installation.....	14
Relay Module Wiring Diagram.....	15
SEER ECU Module Wiring Diagram.....	16
Critical ECU Inputs.....	17
System Test.....	19
Permanent Installation.....	20
Installation Checklist.....	21
Troubleshooting.....	23
Operation Section	
Key Fob Operation.....	25
System Features.....	26
Setup Section	
Key Fob Pairing.....	31
Key Fob Erasing.....	33
Disclaimer & Contact Information.....	34



Skip to Page 25 if you just received this manual after your SEER System professional installation.



Installation Route

Start Here

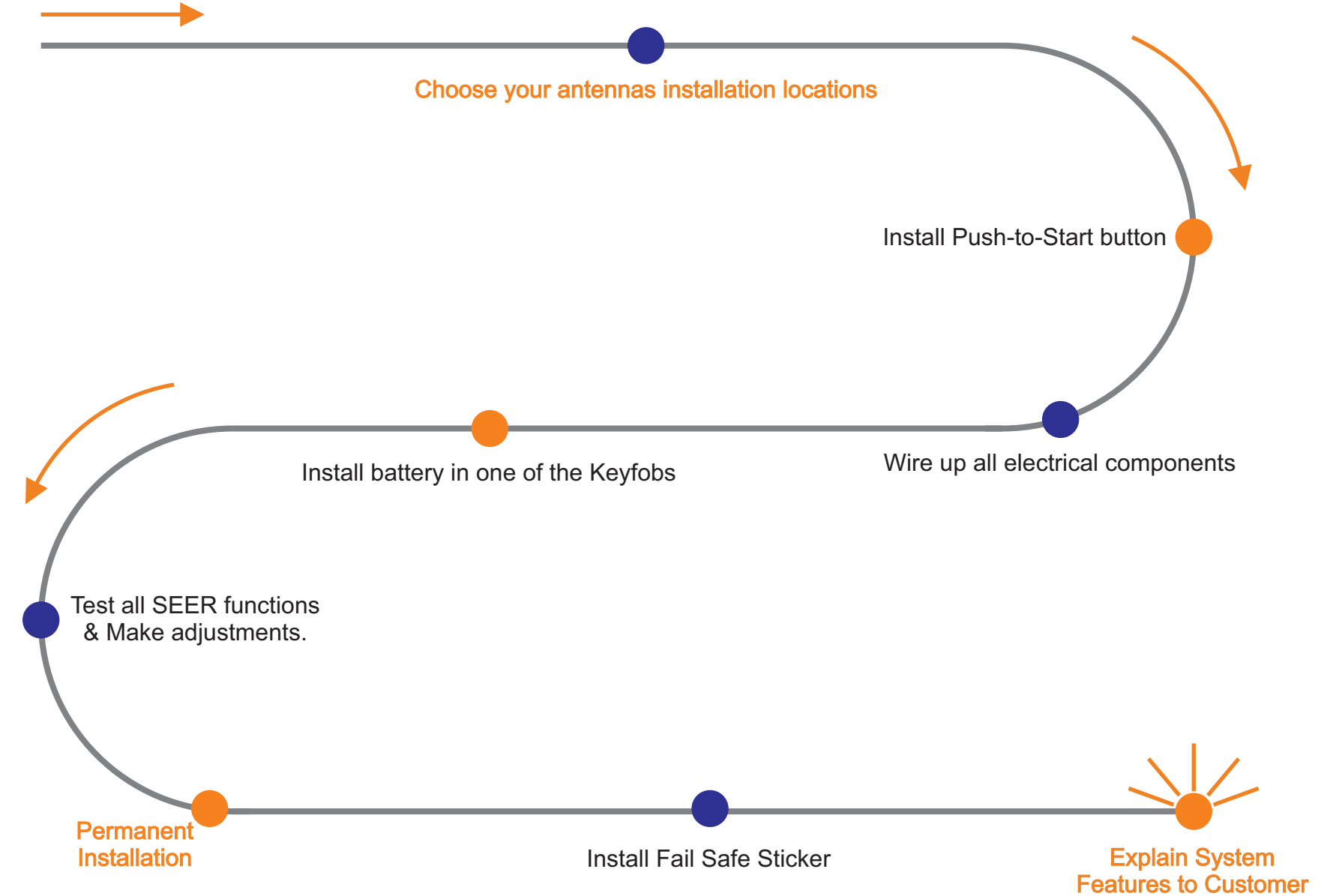

Included Parts

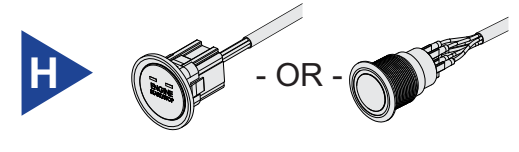
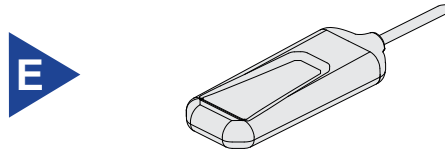
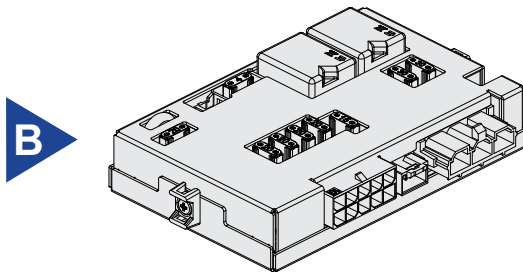
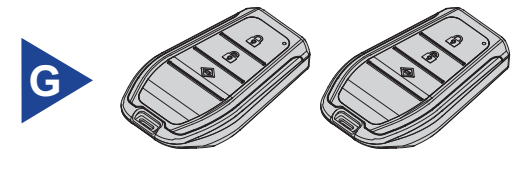
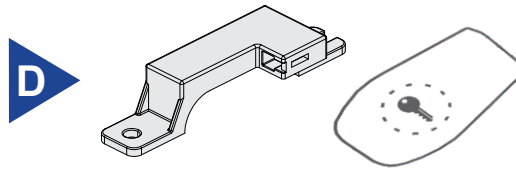
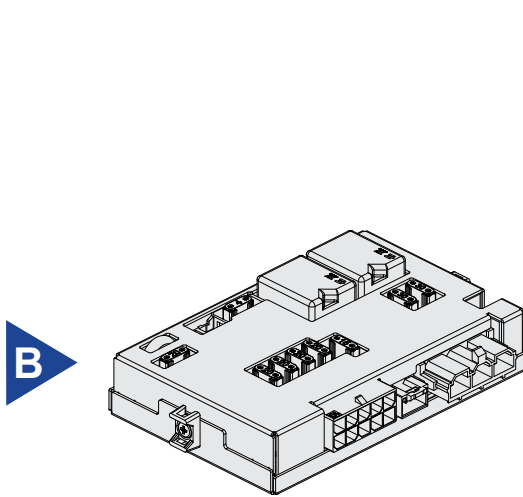
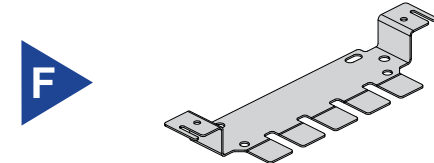
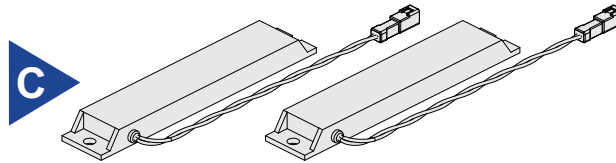
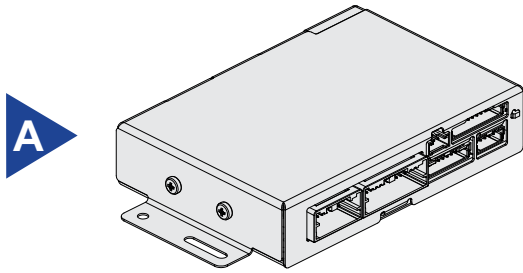

A. SEER ECU

C. Antennas LF1 & LF2

F. LF2 Antenna Bracket

B. Relay Module

D. Antenna LF3 & Sticker

G. Key Fobs

E. RF Antenna

H. Plastic or Metal Push Button

Harnesses

Main Harness

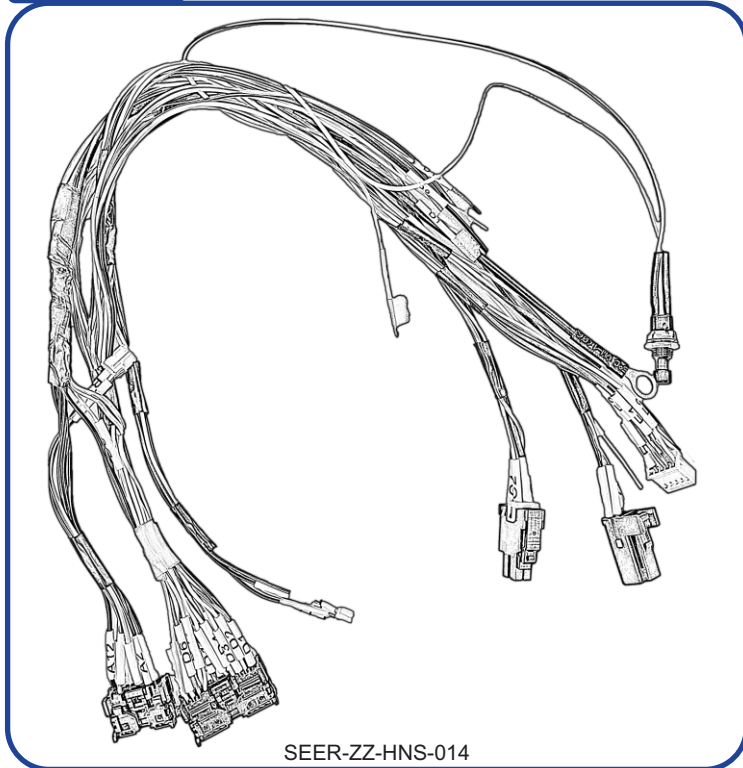

SEER-ZZ-HNS-014

Relay Harnesses

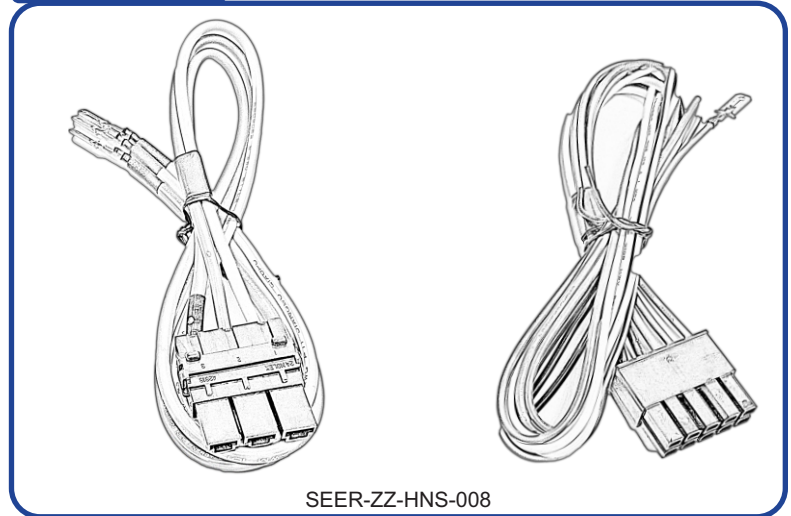

SEER-ZZ-HNS-008

Metal PTS

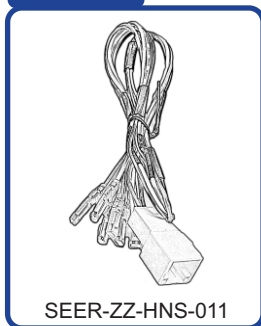

SEER-ZZ-HNS-011

Plastic PTS



SEER-ZZ-HNS-010

Antennas Harness

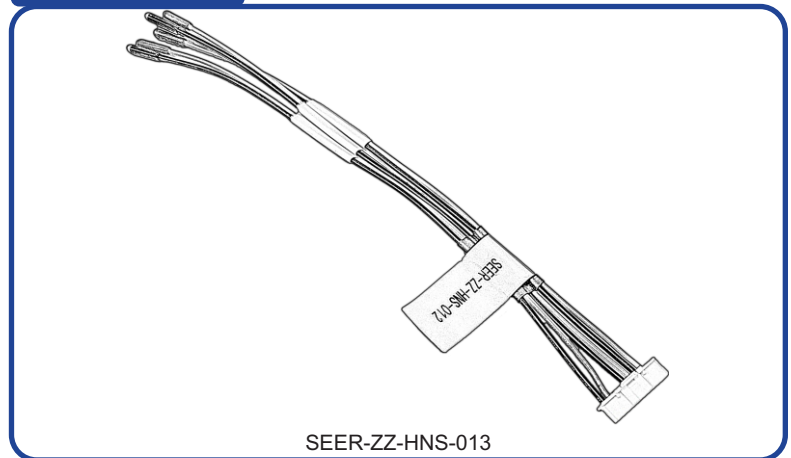

SEER-ZZ-HNS-013

Safety

Read and follow this installation manual in its entirety. You should read and familiarize yourself thoroughly with the following information prior to installing and using this unit. In addition, make sure to read and follow all installation schematics and installation manuals for the product and the vehicle in which it is being installed.

Have the electrical installation performed by a certified electrician. The installation of the wiring for this product requires technical skills and experience of 12V professional installer.

Throughout this manual you will encounter Warning and Caution signs. Warning signs will be color-coded in black. A Warning sign indicates a hazardous situation that, if not avoided, could result in severe injury. Caution signs will be color-coded in gray. A Caution sign indicates a hazardous situation that, if not avoided, could result in equipment damage and/or minor injury.

FCC WARNING

Contains FCC ID: 2BK5KSEERECUA
ISED: 33061-SEERECUA

This device complies with Part 15 of the FCC Rules. Operation is subject to the following two conditions:
(1) This device may not cause harmful interference, and
(2) this device must accept any interference received, including interference that may cause undesired operation. Any changes or modifications not expressly approved by On Semiconductor could void the user's authority to operate the equipment.

WARNING

Do not disassemble or alter any provided part.

WARNING

Do not let the product or any added equipment distract you while driving.

CAUTION

Use only the specified accessories, tools and parts.



INSTALLATION SECTION

ECU Wiring

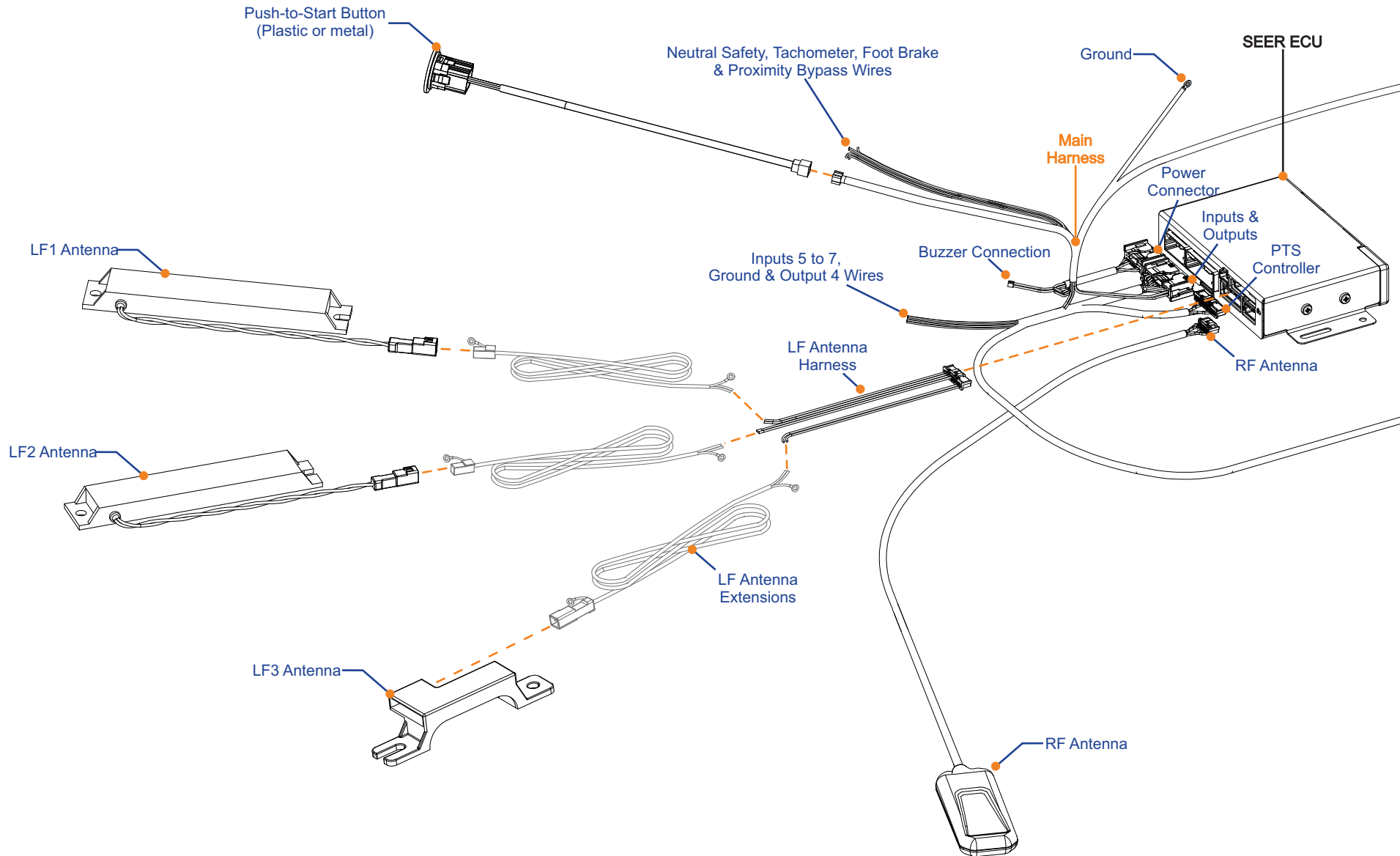

Relay Module Wiring

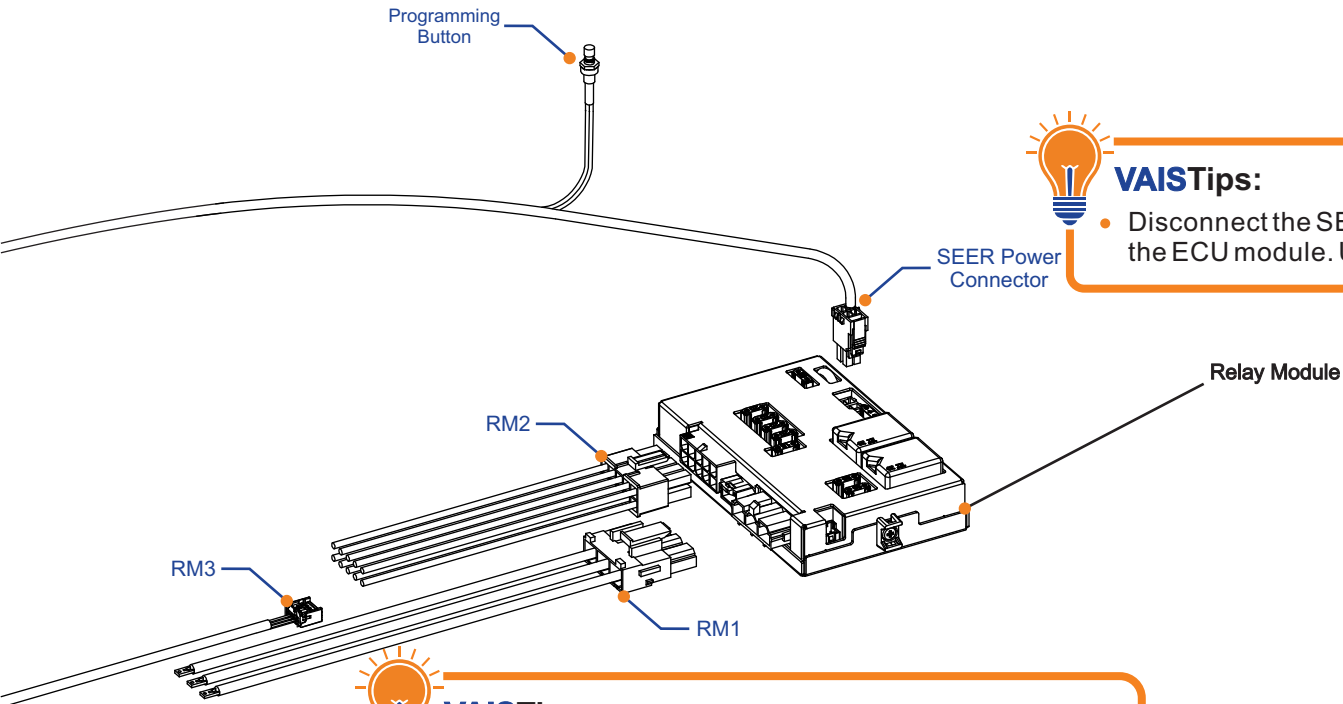

VAITips:

- Disconnect the SEER Power Connector to cut power to the ECU module. Use this to reset your system.



VAITips:

- Disconnecting the RM1 Connector is the quickest and simplest way to cut power to the entire SEER System.
- If you need to disconnect RM2 for any reason, disconnect RM1 first.

CAUTION

NEVER KEEP TWO KEY FOBBS TOGETHER WITHIN THE SEER SYSTEM RANGE.



Antenna Locations

STEP 1

Determine the best location for your antennas. The installation locations for your SEER system antennas will be specific to your car size and shape.

Most vehicles will allow for these locations:

- **LF1:** Under dashboard, as high as possible.
- **LF2:** See diagram.
- **LF3:** Within Dashboard or Center Console
- **RF:** By the windshield, as high as possible.



VAITips:

- **LF3** should be located within the driver's reach. Mount it behind thin panels. Make sure the total distance between the antenna and the back of the Key Fob is **10mm** or less. Keep also in mind that a Sticker noting the location of this antenna will be installed on a later step.
- If your vehicle is a Pickup Truck, the best place to install **LF2** is in between bumper and tailgate.
- The **SEER ECU** location will be determined by your wiring setup. This location will be specific to your car.

STEP 2

Lay out and connect your SEER System. Set all system components where you intend to permanently install them by following the diagrams on this page and the next page as well. This will allow you to visualize your wiring installation and to test your system functionality.

WARNING

DO NOT BLOCK THE AIRBAGS.

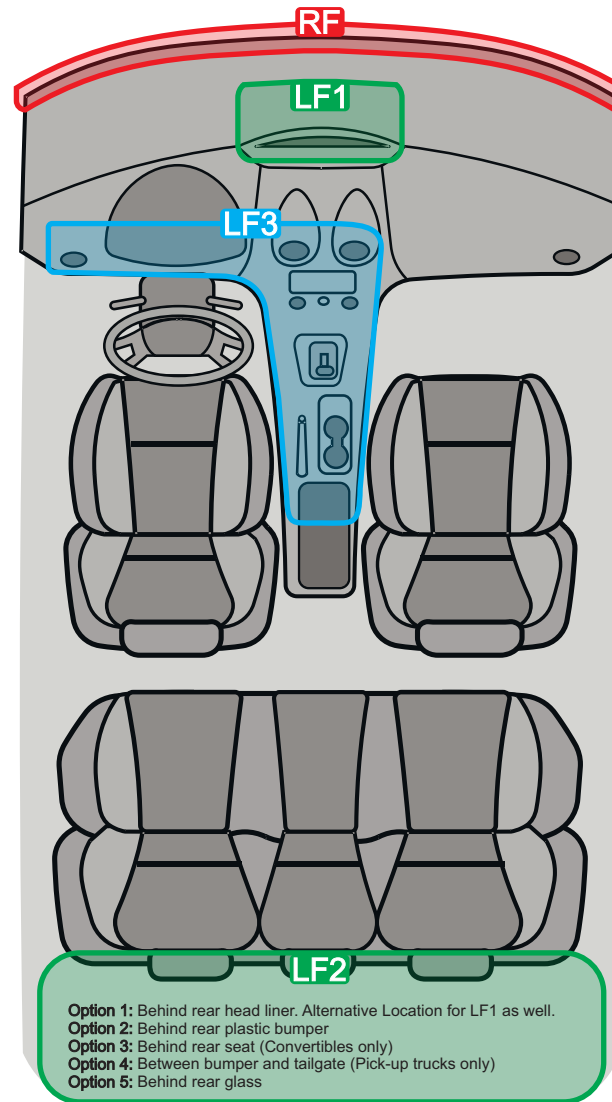

Part drawings

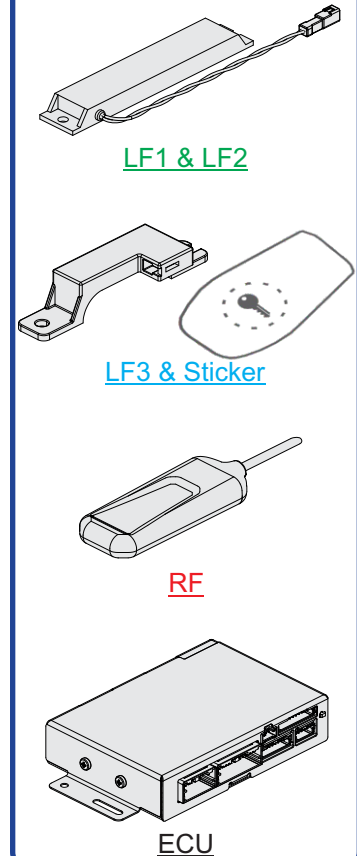

CAUTION

ALL ANTENNAS MUST BE CONNECTED TO THE SEER ECU.
LF3 ANTENNA MUST BE INSTALLED IN A REACHABLE LOCATION. THIS ANTENNA IS USED FOR FAILSAFE FUNCTIONALITY.
DO NOT PLACE ANY ANTENNA UNDER OR BEHIND METAL.

Antenna Locations

Examples of different antenna layouts:

SEDAN OR CONVERTIBLE

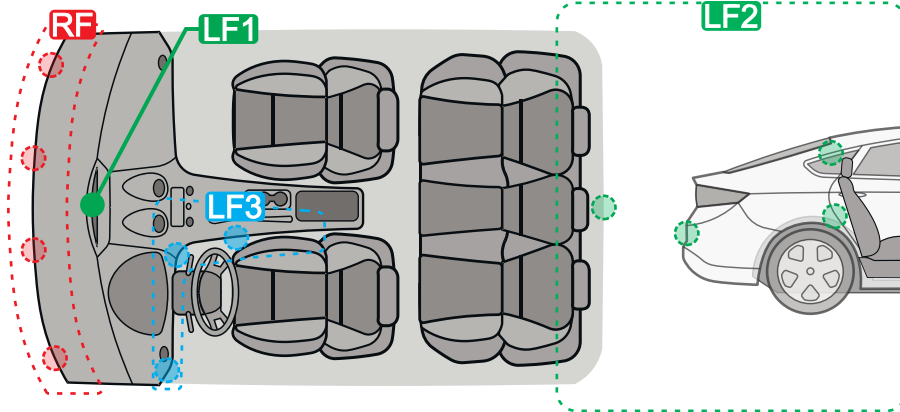

- **LF1**: Centered under dashboard, as high as possible.
- **LF2**: Behind rear seats or rear plastic bumper.
- **LF3**: Within the driver's reach, behind a <10mm thick panel.
- **RF**: By the windshield, as high as possible.

SUV

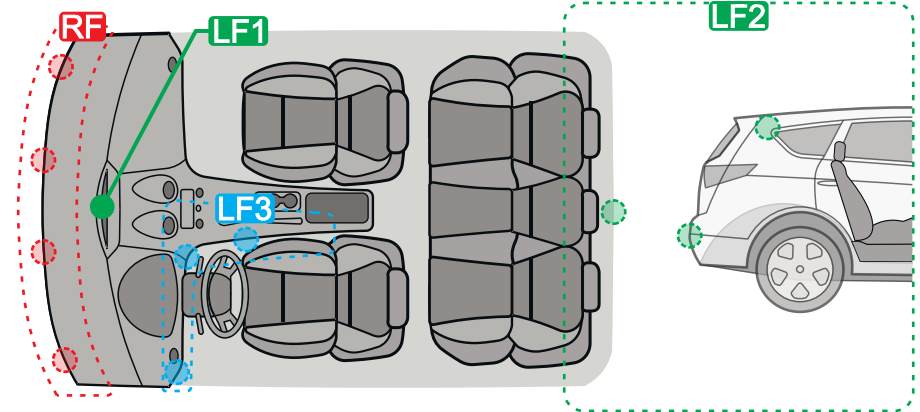

- **LF1**: Centered under dashboard, as high as possible.
- **LF2**: Behind rear seat, up by the headliner or rear plastic bumper.
- **LF3**: Within the driver's reach, behind a <10mm thick panel.
- **RF**: By the windshield, as high as possible.

TRUCKS

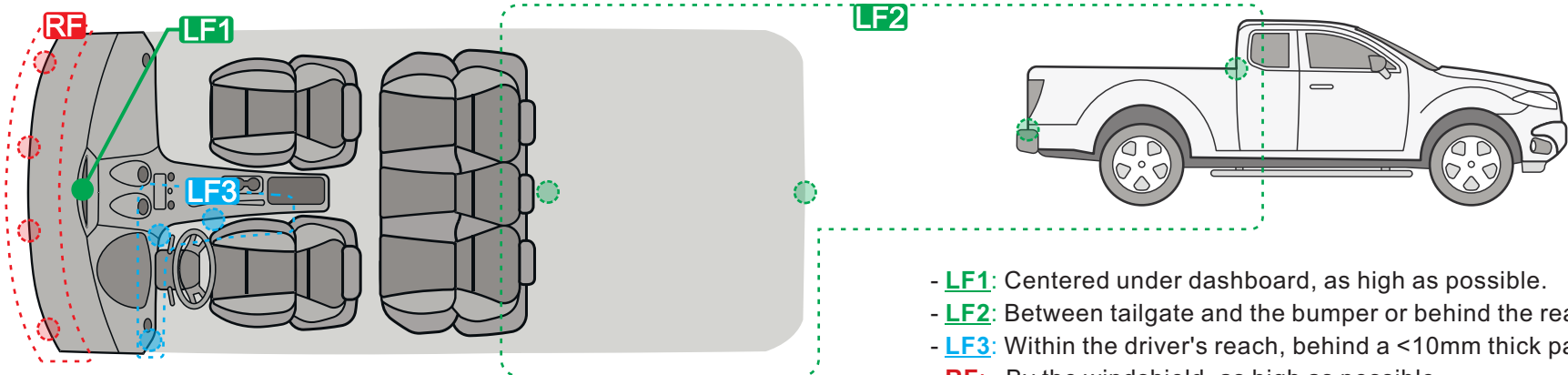

- **LF1**: Centered under dashboard, as high as possible.
- **LF2**: Between tailgate and the bumper or behind the rear glass.
- **LF3**: Within the driver's reach, behind a <10mm thick panel.
- **RF**: By the windshield, as high as possible.

Antenna Placement

STEP 3

Adjust Antennas. Make sure that the antenna wiring, including the extension and harness, do not coil during the installation. Measure and cut the extension cable to length needed.

WARNING

COILED ANTENNA WIRES, DOUBLE GROUNDING OR NO GROUNDING WILL CAUSE SEER SYSTEM MALFUNCTION OR INTERFERENCE WITH VEHICLE'S FACTORY WIRING.



VAIS Tips:

- Soldering will greatly improve the system functionality. We recommend you solder all antenna connections both for testing your setup and for the permanent installation as well.
- Make sure to install the LF3 Antenna with its sticker installation in mind. See Page 19 for more details.
- An optional bracket for the LF2 antenna is provided to aid in certain installation scenarios. Its use is recommended when the antenna is unavoidably close to metal surfaces.

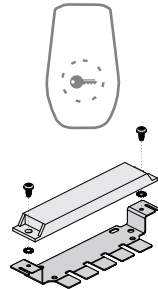

STEP 4

Double check metal clearances. All antennas must be kept away from metal surfaces.

Make sure that the distance between the antennas and any metal surface is **at least greater than 1 inch**.

Avoiding positioning antennas in corners where metal frames are present on two or three sides, as this will interfere with their performance.

Poor Antenna Installation

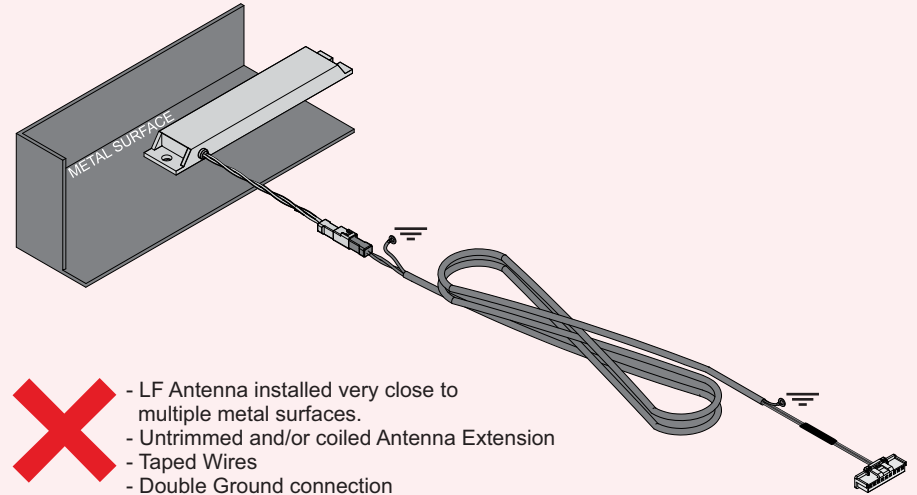

Proper Antenna Installation

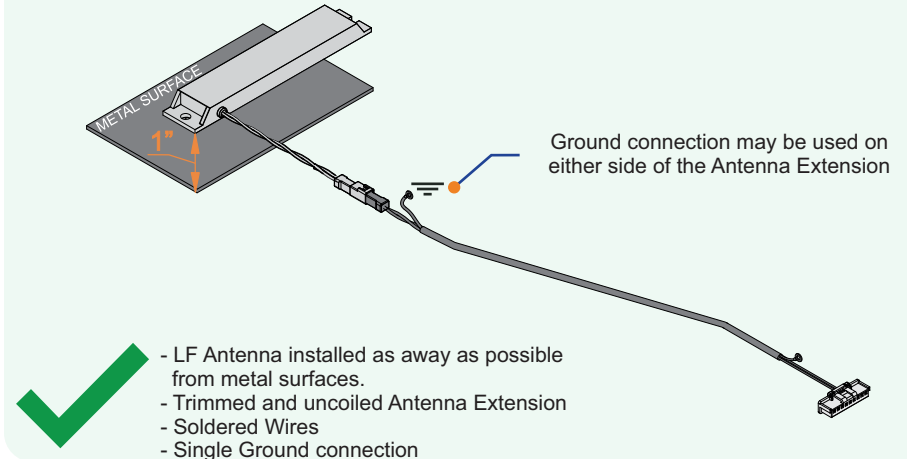

PTS Button Install

STEP 5

Install your Push-to-Start button. Keep the length of all harnesses and the SEER ECU location in mind when choosing your Push-to-Start button's location.

Install plastic button by simply pushing it through the dashboard. To install the metal button, make use of the provided nut.

Metal Button kit integrated into the steering wheel column can be purchased through www.ididit.com. Contact Ididit for more information.

WARNING

DO NOT INSTALL THIS SYSTEM IF YOUR CAR HAS A STEERING WHEEL LOCK.

CAUTION

VAIS Technology is not responsible for any vehicle damage or injuries caused by removing a car's steering wheel steering lock mechanism.

STEP 6

Wire Relay Module. Follow the diagrams on the next pages to fully wire up your Relay Module and SEER ECU.

Do not connect battery power yet.

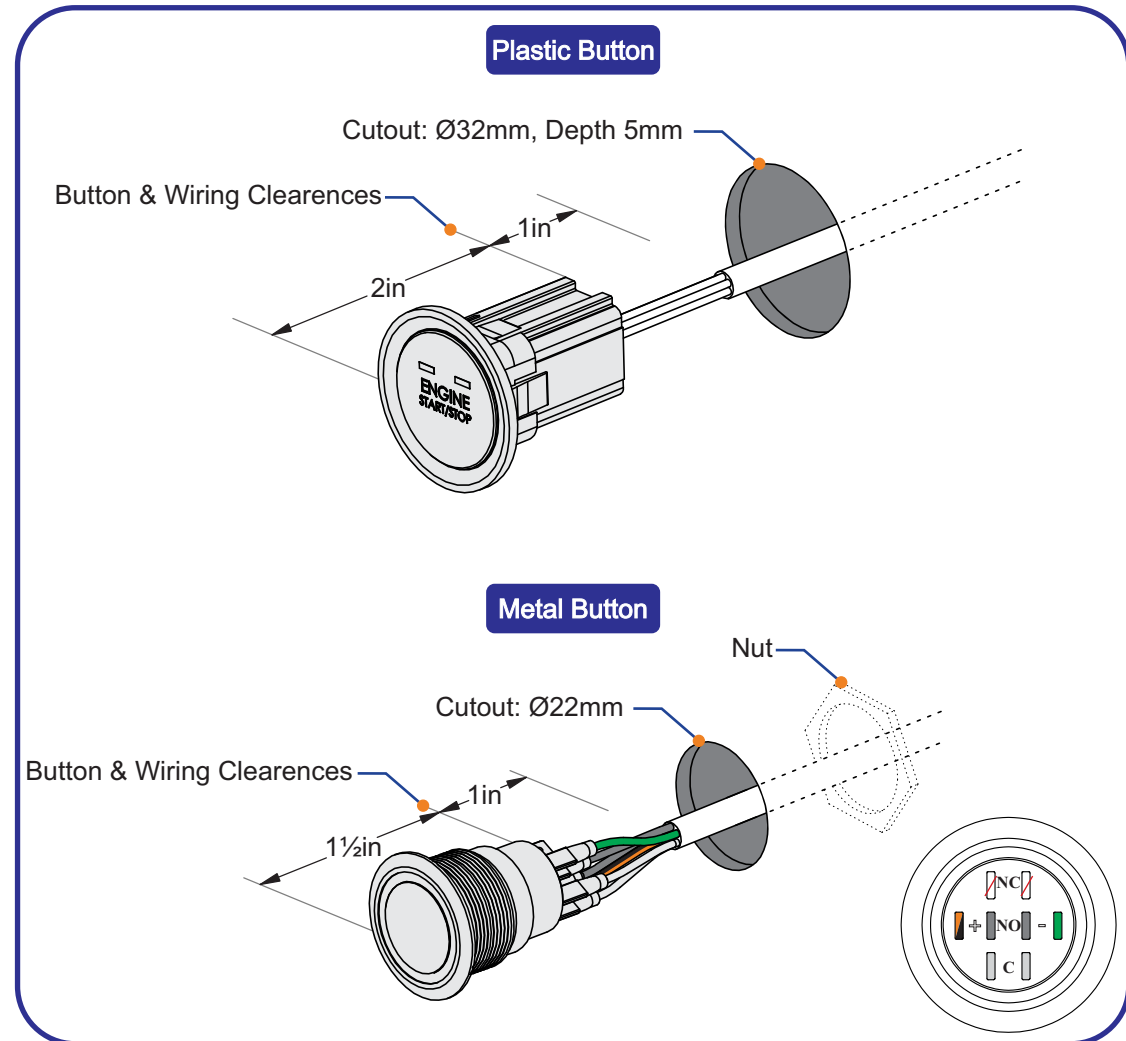

Relay Module Wiring

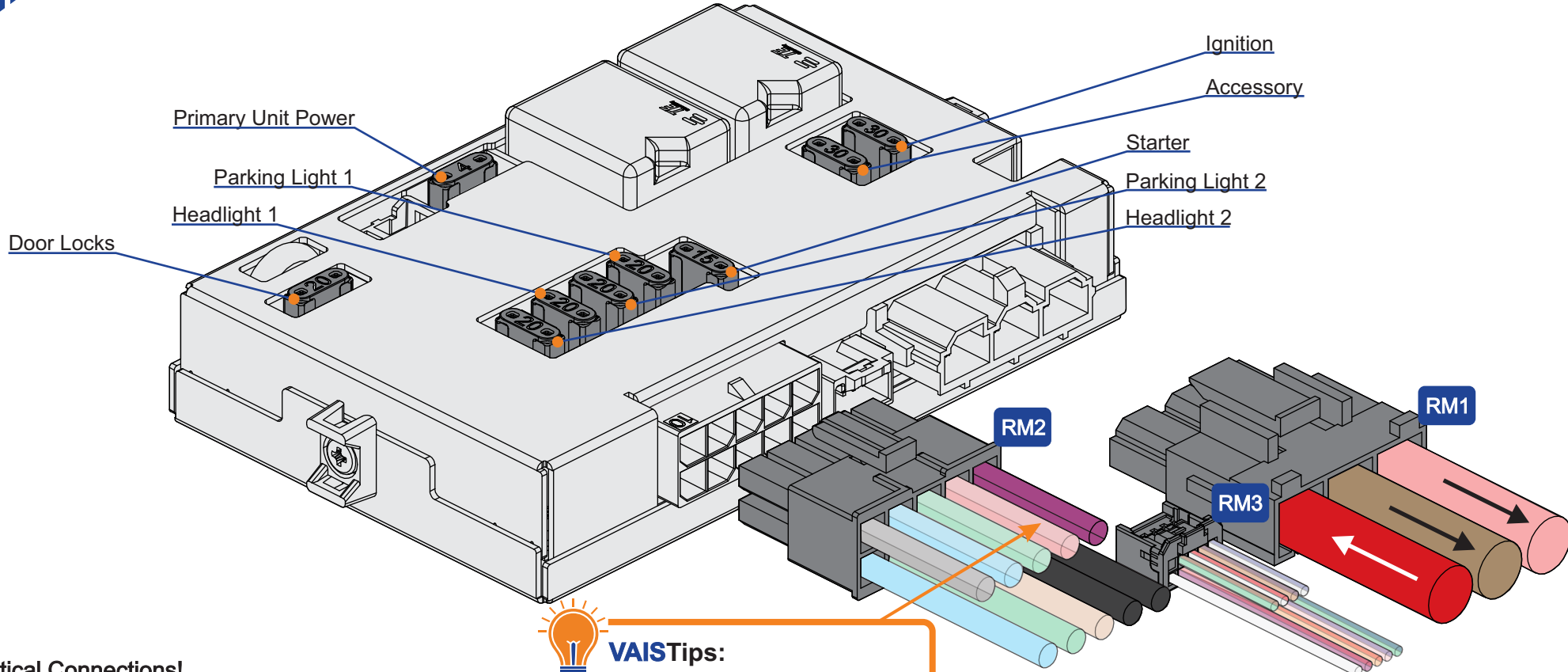

Critical Connections!
*Optional Connections**
 [Wired within Harness]



VAITips:

- Connect RM2's purple wire directly to the car's starter solenoid.

RM2 - Outputs

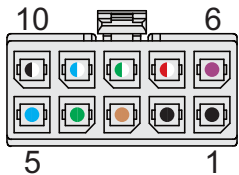

Pin	Function	Current
1 ●	Ground !	Ground
2 ●	Ground !	Ground
3 ●	Horn / Siren *	5A (-)
4 ●	Lock *	20A (+)
5 ●	Unlock *	20A (+)
6 ●	Starter !	15A (+)
7 ●	Parking Light 1 *	20A (+)
8 ●	Parking Light 2 *	20A (+)
9 ●	Headlight 1 *	20A (+)
10 ●	Headlight 2 *	20A (+)

RM3 - Inputs

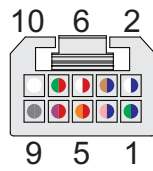

Pin	Function
1 ●	[Ignition] (-)
2 ●	[Accessory] (-)
3 ●	[Starter] (-)
4 ●	[Lock] (-)
5 ●	[Unlock] (-)
6 ●	[Horn / Siren] (-)
7 ●	[Parking Light] (-)
8 ●	[Headlights] (-)
9 ●	[Relay Jumper] (-)
10 ○	[Jumper Slot] (-)

RM1

Pin #	Function	Current
1	Ignition ! (Output)	30A (+)
2	Accessory ! (Output)	30A (+)
3	Car Battery ! (Input)	12V Constant

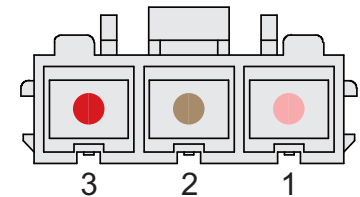



VAISTips:

- Contact us for advanced optional setups

ECU Wiring

Power

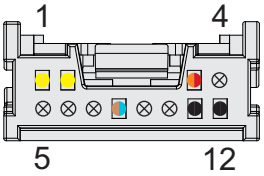

Pin	Function
1	[Power Supply]
2	[Power Supply]
3	[Buzzer Output] (+) / 300mA
4	⊗
5	
6	⊗
7	⊗
8	[Buzzer Output] (-) / 300mA
9	⊗
10	⊗
11	Ground !
12	Ground !

LF Antennas

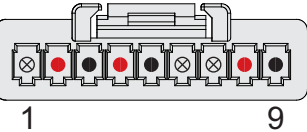

Pin	Function
1	⊗
2	[LF1] (+20V)
3	[LF1] (-20V)
4	[LF2] (+20V)
5	[LF2] (-20V)
6	⊗
7	⊗
8	[LF3] (+20V)
9	[LF3] (-20V)

Inputs / Outputs

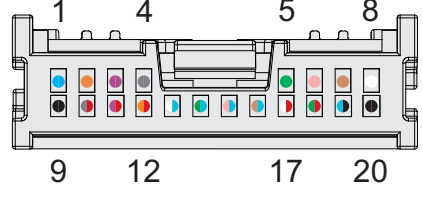

Pin	Wire Color	Input/Output	Function	Amperage	Pin	Wire Color	Input/Output	Function	Amperage
1	●	[Input 7]	Prog. Button	/	11	●	[Output 5]	Parking Lights	500mA
2	●	Input 6*	/	/	12	●	[Output 6]	Unlock (-)	500mA
3	●	Input 5*	/	/	13	●	[Output 0]	Accessory (-)	1000mA
4	●	Input 4 !	Neutral Safety	/	14	●	[Output 1]	Ignition (-)	1000mA
5	●	Input 1 !	Foot Brake	/	15	●	[Output 2]	Starter (-)	1000mA
6	●	[Input 2]	PTS Button	/	16	●	[Output 3]	Lock (-)	1000mA
7	●	Input 3 !	Tachometer	/	17	●	[Output 7]	Horn (-)	500mA
8	○	[Input 0]	Ignition	/	18	●	[Output 8]	Headlights	500mA
9	●	!	Ground	/	19	●	Input 8 *	Proximity Bypass	/
10	●	Output 4*	Key Fob Button	500mA	20	●	!	Ground	/

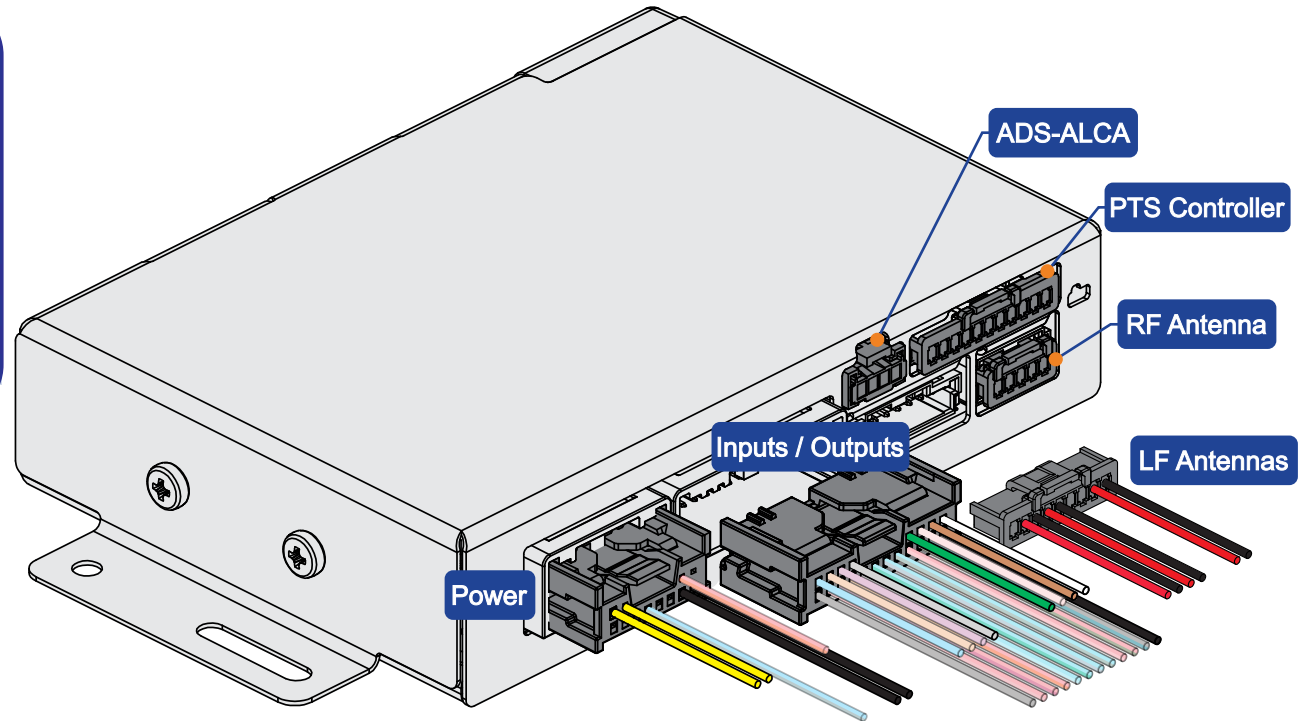

Critical Connections!
Optional Connections*
[Wired within Harness]

Critical ECU Inputs

STEP 7

Neutral Safety / Park Position Input Installation.

This feature allows the SEER system to:

- Start/Stop the engine only when the transmission is in Park/Neutral and the brake pedal is pressed.
- Prohibit the Start/Stop of the engine while the transmission is in Drive or any other gear.

For the Neutral Safety feature to work properly, the SEER ECU needs input from a wire in your vehicle with a Ground (-) signal that changes to signal absence.

Ground Signal (-)
While Parked



Signal Absence while
on Neutral or Gear

Determine what type of installation applies to your car and follow said instructions.

WARNING

VAIS TECHNOLOGY IS NOT RESPONSIBLE FOR ANY MODIFICATIONS MADE TO THE VEHICLE SAFETY EQUIPMENT



VAIS Tips:

- Make sure to always isolate any left-over wiring using electrician's tape.
- If none of these installation options suit your specific car's electric wiring, please contact us.

Cars with a dedicated Neutral Safety Signal

Newer cars have a dedicated Park Position or Neutral Safety signal. Please refer to your car's service manual to determine where this wire is located. Once you locate this wire, simply tap into it and connect it as shown below.

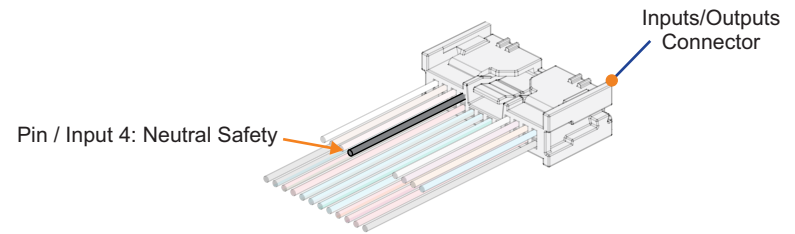

Cars with combined Starter and Neutral Safety

On these cars, the use of the starter wire as a neutral safety signal is advised. To achieve this using only your SEER equipment: loop together and isolate the Purple and Gray wires coming from the long strip of wires next to the PTS connector on your main harness.

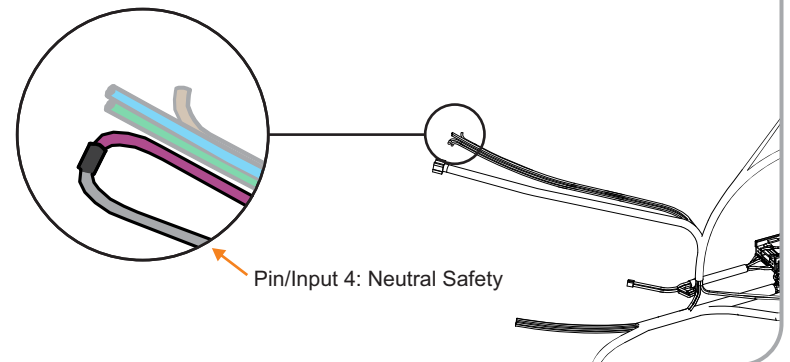

Critical ECU Inputs

STEP 8

Tachometer and brake pedal signals installation.

Locate the wires in your car containing these two signals. Both signals are crucial for proper SEER system operation.

- Tachometer Signal. Provide a signal between 3V and 12V. The system may accept a signal with voltage spike of up to 80V. If measured with voltmeter, ensure the voltmeter is set to AC mode for accurate measurements. If measured with the scope, focus on positive segment of the signal only.
- Brake Pedal. Provide a 12V signal. This signal allows the system to prevent engine start without pressing the brake pedal first.

WARNING

DO NOT CONNECT TACH INPUT TO A HIGH-VOLTAGE COIL.

Optional STEP

Proximity Bypass Signal installation. The proximity feature of your SEER system may be disabled temporarily by providing Input 8 with a 12V signal. Typically, the Door Status signal fits this feature best.

By default, when a 12V signal is provided to Input 8, the SEER system will not lock or unlock regardless of the location of the Key Fob.

SEER ECU Inputs/Outputs Connector

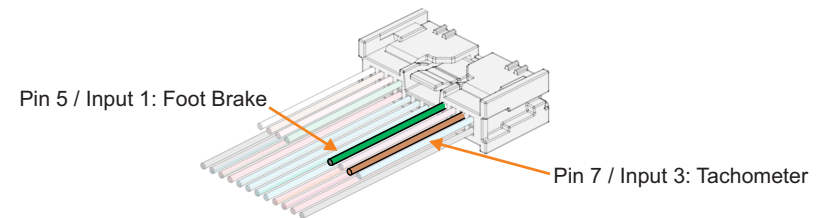

SEER ECU Inputs/Outputs Connector

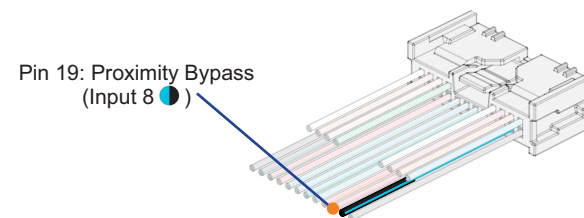

System Test

STEP 9

Confirm that your antenna layout, wiring routing and connections work as intended. Perform the following procedure to test your SEER system:

1. Confirm all SEER components and harnesses have been connected.
2. Make sure your ground and power wiring coming from your car's battery are the last two connections.
3. Install a battery in one of the Key Fobs. **Do not install a battery in both Key Fobs.**
4. Test all applicable SEER system features, such as:
 - All Key Fob's buttons
 - Ignition
 - Approach & Departure
 - Shutdown
 - Accessory
 - Start
5. Depending on the specific inputs and outputs you have connected to the SEER system you might need to check the functionality of other features.
6. Install the second Key Fob's battery and test all features again with it. **Make sure to keep the first Key Fob at least 50' away from the vehicle while performing this test.**
7. Perform any wiring or antenna adjustments as needed.

CAUTION

Never cut away cable insulation to supply power to other equipment.

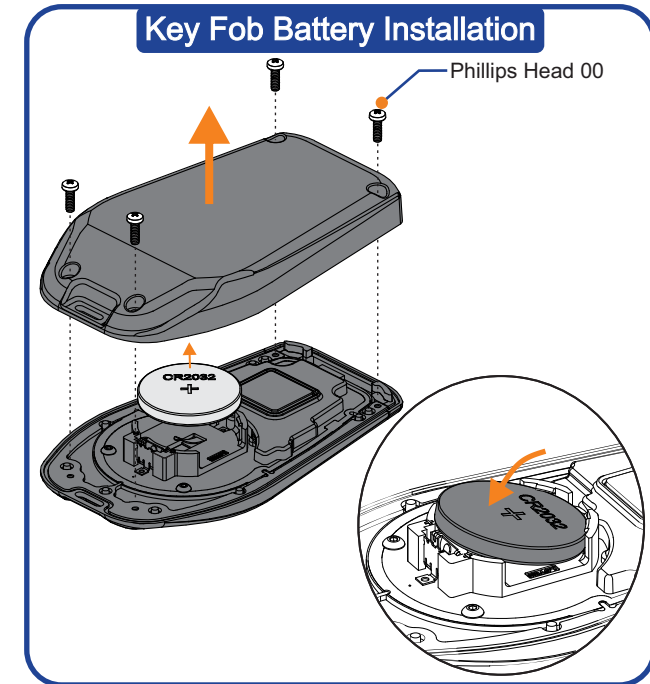

WARNING

DO NOT ALLOW CABLES TO BECOME ENTANGLED IN SURROUNDING OBJECTS.



VAITips:

- Try a few different spots for your antennas.

Moving antennas slightly can greatly improve its signal due to the antennas being highly affected by metal surfaces.

Permanent Installation

STEP 10

Permanently install all SEER components. Clean up any loose wiring, secure all harnesses to the vehicle and make sure the Relay Module and SEER ECU are installed securely.

Double check all electrical connections are secured with soldering.



VAITips:

- Keep in mind panel thickness when selecting your installation location. The maximum distance between antenna LF3 and the Key Fob is 10mm.

STEP 11

Install **Failsafe Sticker**. Locate the panel where Antenna LF3 will be installed permanently.

With the use of magnetic hardware, like a telescoping magnet and a common disk magnet, mark the position where the antenna will be located **on both sides of the panel**.



VAITips:

- If possible, drill into the car panel to mark the exact location of where the antenna and sticker will meet.

Install the provided sticker using your mark as a guide. **The Sticker's Key Symbol and the square area on Antenna LF3 must be as closely aligned as possible**, as shown in the diagrams.

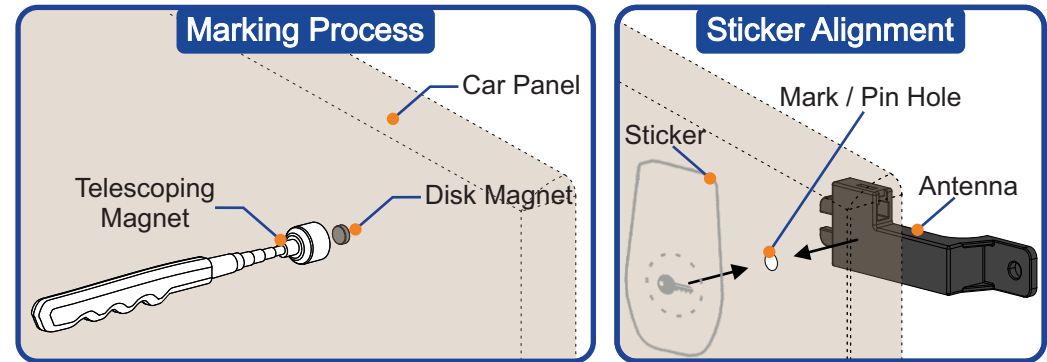

CAUTION

DOUBLE CHECK ALIGNMENT BETWEEN ANTENNA AND STICKER

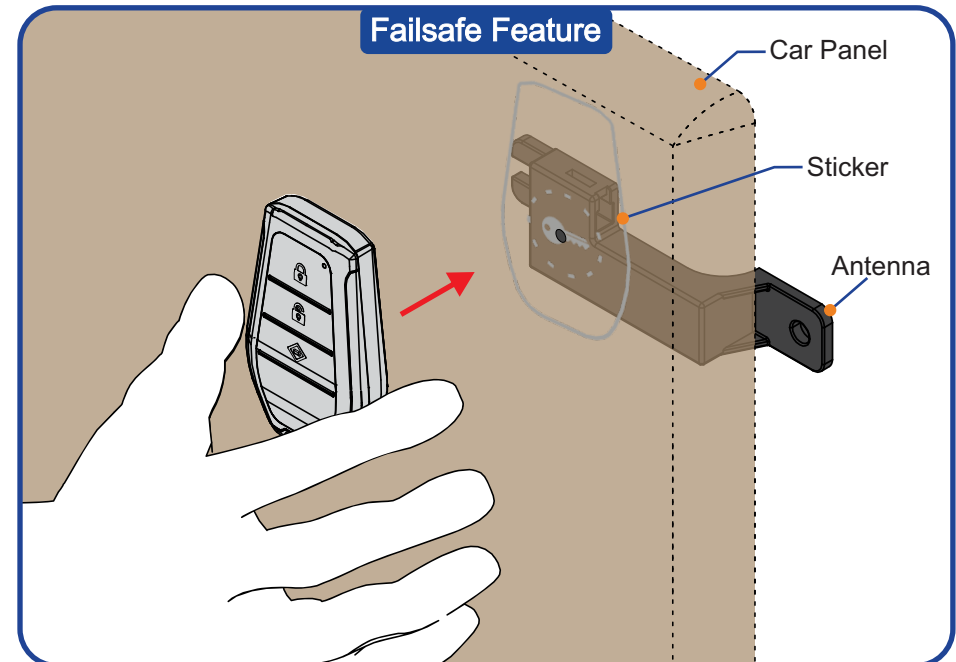

Finish the Installation

STEP 12

Programming button installation. Make sure the programming button attached to the main harness is installed inside the vehicle, ideally hidden from plain sight but yet easily accessible to the customer.

It's accessibility is dependant on the Relay Module installation location. Relocate SEER system parts as necessary to make this button accessible.

STEP 13

Perform a last test. Once all car panels have been installed back and you have finished installing all SEER system parts, perform a last test to confirm all system features work as intended.

STEP 14

Complete the following checklist.

- All SEER components have been installed.
- All SEER system features have been tested for proper functionality.
- All SEER features have been explained to the customer.
- Operation Manual has been handed to the customer.

Programming Button

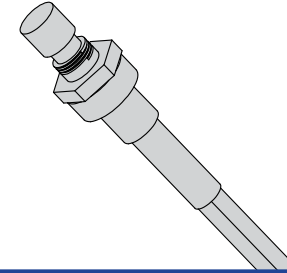



Troubleshooting

Symptoms

1 PTS button lights up green when pressing the foot brake pedal while the Engine is on.

2 System tries to re-crank when pressing PTS button while the Engine is on.

3 Can't shut off the vehicle

4 No activity and ECU double-beeps when PTS button is pressed.

5 Car not locking or unlocking with Approach and Departure feature or Key Fob buttons.

6 Erratic behavior (including lock/unlock or no start)

Check

1. Tach Signal wire may not be connected properly.
2. Tach Signal may be out of correct voltage range.

1. Tach Signal may not be connected properly.
2. Tach Signal may be out of correct voltage range.
3. Try a crank position sensor as tach signal.
4. Neutral Safety connection may not be properly installed. See page 19
5. Tachometer signal may not be properly installed or is not being recognized. See Page 20.

1. Park Position signal may not be connected.
2. Park Position signal may not be switching between ground and no signal present.
3. Gear Shifter may not be giving ground signal in park or neutral positions.
4. Clutch Pedal may not be fully depressed or not giving ground signal.
5. If none of the above solve your issue, you may use an emergency override by pressing and holding Push to Start Button for 3 seconds.

1. Key Fob may not be inside the vehicle, not close enough to antenna LF3 or it's signal may be blocked."
2. LF3 Antenna may not be connected.
3. Check and or replace batteries in the Key Fob.
4. Key Fob Placement. Key Fob might be blocking LF or RF antenna signals.

1. Verify all antennas are connected as instructed in this manual.
2. Power cycle ECU with antennas plugged in.
3. Verify wire connections for Lock and Unlock inputs and outputs.

1. Antennas may be blocked by metal. Confirm all antennas are installed as instructed in this manual and at least 1" away from any solid metal surface.
2. Antennas may have been painted. DO NOT PAINT ANY ANTENNAS
3. Both Key Fobs are active, close to each other and within the car's proximity.
4. Make sure Key Fob battery is charged.
5. Check ALL SYSTEM GROUNDS from ECU, relay module and any other grounding points or Drain wires.



OPERATION SECTION

Key Fob

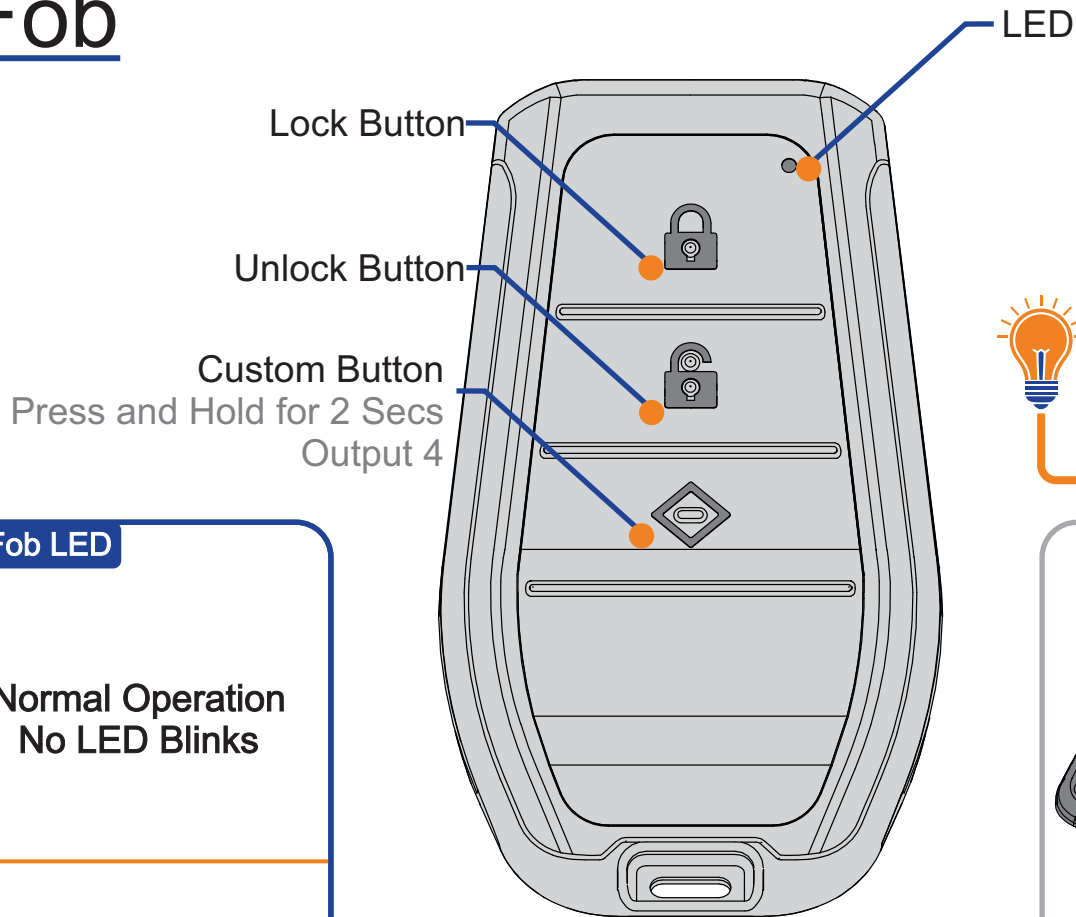

VAIS Tips:

- Use the removal tool to safely swap your Key Fob battery CR2032.

Key Fob LED

Normal Operation
No LED Blinks

Low Battery
LED blink with
every button press

Keyfob Battery Replacement

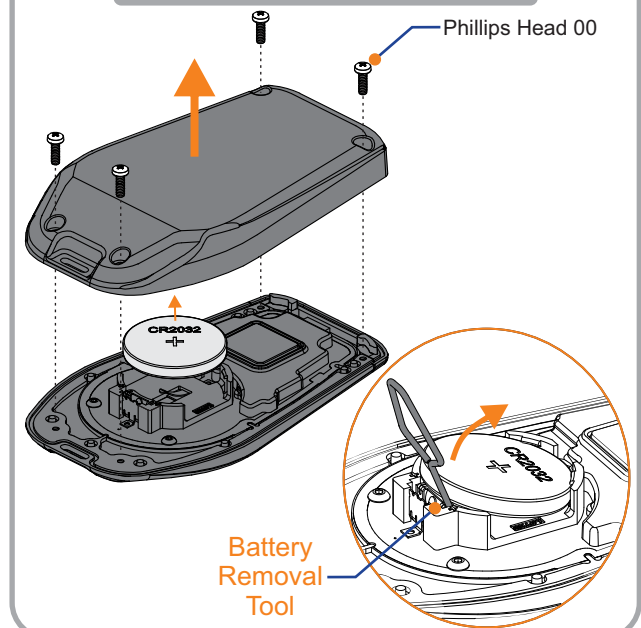

! Never use two Key Fobs at the same time. Always keep one of the Keyfobs away from the car.

Approach and Departure

Your SEER system uses its multiple antennas and your Key Fob to know whether you're close or far away from your car. The system can activate different features depending on the direction you're moving.



! Although your SEER system is capable of performing all features listed on this page, the features available to you are dependant on your car capabilities and professional installation.

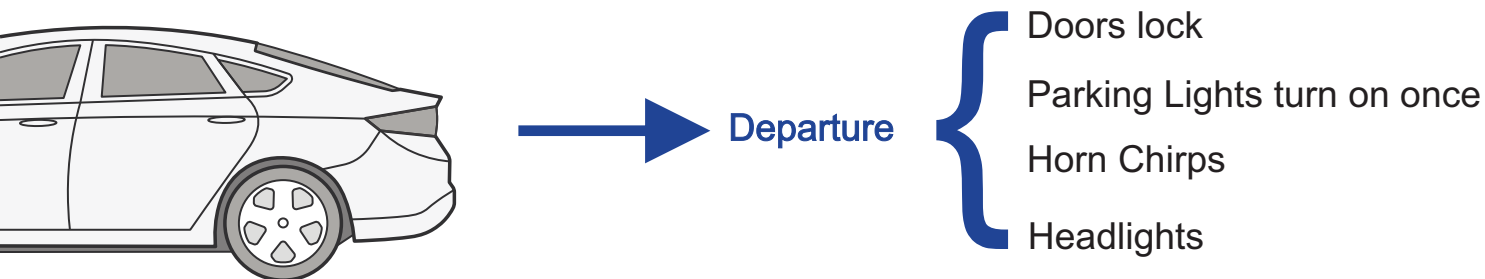

Features

Button Status LEDs

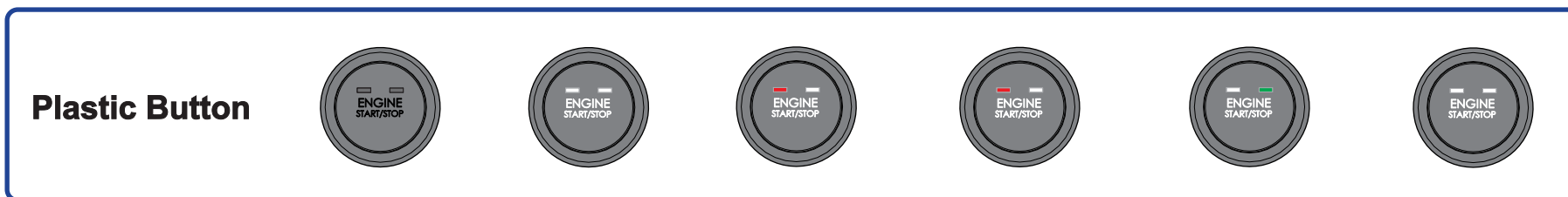
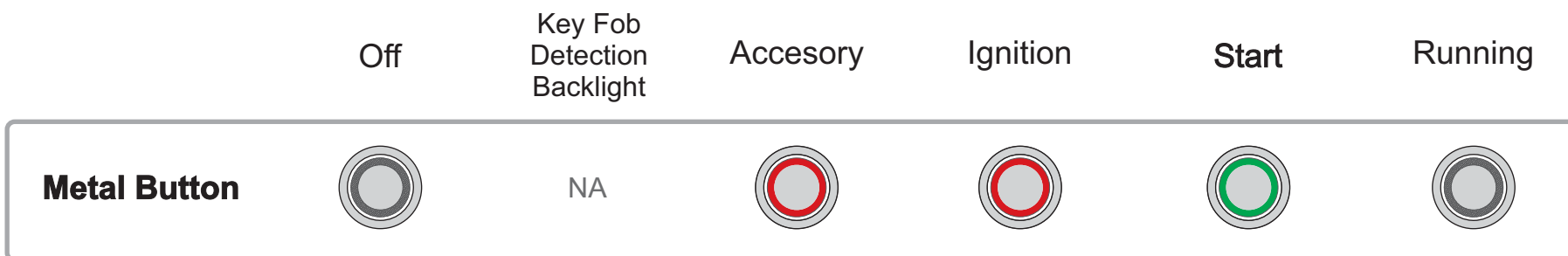

! Press and hold the Start Button for 3 seconds to emergency shut-off your car.

SleepMode

This mode is designed to save your car's and Key Fob's batteries. It's designed to activate itself whenever the system is not being used. Your Key Fob will go into Sleep Mode first, followed by your whole SEER system as outlined below:

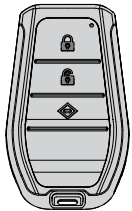

After
90
seconds

Of Key Fob movement inactivity, Key Fob Sleep Mode will be triggered. If your Key Fob is outside the car, the car's doors will lock. Move your Key Fob or press any button wake up it up.

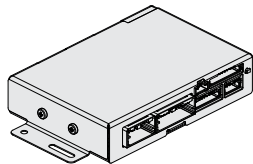

After
36
hours

Of SEER system inactivity, communication with the Key Fob is reduced slightly. Press any button on your Key Fob to wake up the system. Expect delays in the functionality of your SEER system during this time.









After
72
hours

Of SEER system inactivity, system communication is reduced further. Expect greater delays in functionality. Press any button on your Key Fob to wake up the system.

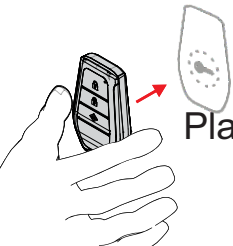
Features

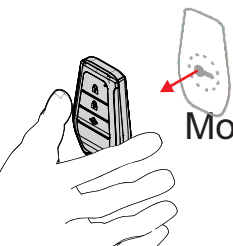
FailSafe

This feature allows you to start your car even when your Key Fob battery has run out. Follow the steps below to use the Fail Safe feature. Make sure to use this feature when your car is shut off, with gear selector in park position and foot brake is not pressed.

-  Press and hold the Start Button until the **LED blinks red**.
Then let go of the button → The LED will now **blink green**.
-  Place Key Fob on the Fail Safe Sticker within 30 seconds ⌚ of the LED blinking green.
Wait until the LED stops blinking ⌚ to remove Key Fob away from sticker.
-  Move Key Fob away from the sticker.
-  Start your car within 15 seconds ⌚ after moving Key Fob away from the sticker.

! If you miss the 15 second window, the Push-to-Start Button will blink green once indicating the Fail Safe Mode has ended. Go back to Step 1 if you miss this window.



SETUP SECTION

Setup

KeyFobPairing

Follow the steps below to pair a new Key Fob. After successfully pairing a new Key Fob, all previously paired Key Fobs will be erased. Before you start, make sure all Key Fobs are out of the car.

1

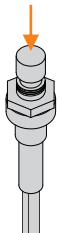

Quickly press the Programming Button **seven (7) times**. You'll hear a short beep  after each press.

↳ A long beep will indicate you've entered pairing mode. After this, you'll have 2 minutes to pair your Key Fob.

2

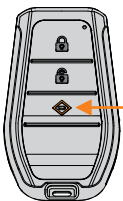

Press and hold the Custom  Button

↳ Without releasing the Custom Button

→ Press Unlock  Button three times then release the Custom Button.



3

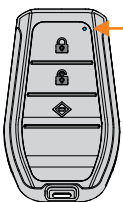

Confirm Key Fob **LED is blinking blue**. If not, go back to **Step 2**.

CAUTION

NEVER KEEP TWO KEY FOBS TOGETHER WITHIN THE SEER



! After successfully pairing a new Key Fob, all previously paired Key Fobs will be erased. If you'd like to pair a second Key Fob it must be paired within the same session.

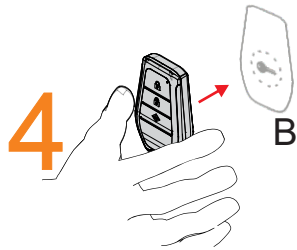

4 Bring Key Fob within 6" to 8" of your Fail Safe Sticker.

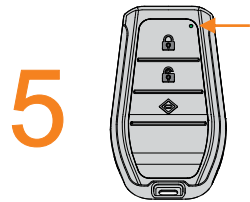

5 Wait until Key Fob LED **blinks green** and you hear the SEER system beep  Successful pairing.

↳ If LED **blinks red** or you don't hear a beep, pairing has failed. Move Key Fob 3ft away of the Fail Safe Sticker and go back to **Step 4**.



6 Go back to **Step 2** to pair your second Key Fob within two minutes of pairing the first Key Fob.



7 After you've paired both Key Fobs wait until you hear a long beep  before starting using your system. This may take up to 2 min.

Setup

KeyFobErasing

To erase all Key Fobs stored in your SEER system perform the following:

1

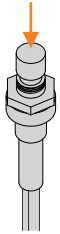

Quickly press the Programming Button **fifteen (15) times**. You'll hear a short beep  after each press.

↳ After the 15th press, you'll hear a long beep indicating your Key Fobs have been erased.



This is a specially useful feature if you have lost all your Key Fobs.

Vais technology is not responsible for or liable for any installation cost, property loss, damages whatsoever, including but not limited to, any consequential damages, incidental damages, loss of time, loss of earnings, commercial loss, loss of economic opportunity and the like that may or may not be resulted from the operation of the seer product(s). Manufacturer does offer a limited warranty to replace or repair the control module. See warranty for more information.

Warranty is available for download at: <https://vaistech.com/download/15244/>



For the most recent version of this document visit <https://vaistech.com/download/48445> or scan the QR code.

CONTACT US



vaistech.com



720-733-2348



sales@vaistech.com



VAIS Technology
8811 American Way, Unit 125
Englewood, CO, 80112



SEER-MAN-004-D4-0825
SEER-PS3-K01
SEER-PS4-K01